

OUR MISSION

"AS LEADERS IN THE FRP INDUSTRY, WE ARE DEDICATED TO CUSTOMER SERVICE AND SUPPORT OF ALL MARKET SECTORS THROUGH CONTINUOUS ENGINEERING ADVANCEMENTS AND PRODUCT DEVELOPMENT. WE STRIVE TO PROMOTE AND MAINTAIN A SAFE, EFFICIENT AND COHESIVE WORK ENVIRONMENT THAT IS GOVERNED BY OUR CORE VALUES TO ENSURE THE BEST POSSIBLE OUTCOME FOR ALL."



AIMS FRP (fiberglass) Retrofit Bridge Rail System is proprietary. It is the first MASH TL4 certified FRP retrofit bridge rail system. The rail is comprised of the FRP structural member, a 316L Stainless Steel internal tube structural member and EPU. The AIMS FRP Rail was developed by AIMS and is patent pending USPTO 15/829,674.

The FRP structural member is inclusive of a pultruded fiberglass-reinforced plastic (FRP) structural shape with a round main cavity a sacrificial rectangular outer cavity for energy absorption. The resin is Fire-retardant Isophthalic Polyester. The rail lengths are customized to order with posts spacings of 8' +/- (2.44 m).



- MASH TL4 crash tested approved
- 100% electrically non-conductive
- 100% corrosion resistant
- Material color throughout product
- Can be manufactured in any color
- Does not spark when impacted by steel
- 3 x the lifespan of galvanized steel
- UV stable
- 316L or galvanized steel posts
- Better energy absorption performance over steel
- Weight of AIMS Rail System is over 2/3 lighter than complete steel
- UV Resistance ...Tested per ASTM G154
- Higher return on investment than steel

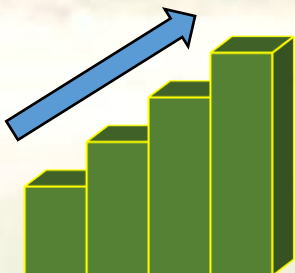

ROI

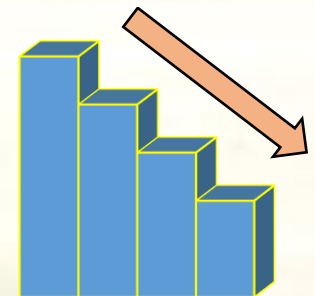

Maintenance Cost

WWW.AIMS-Intl.com

(281) 590-3240

AIMS FRP Retrofit Bridge Rail System (Proprietary)

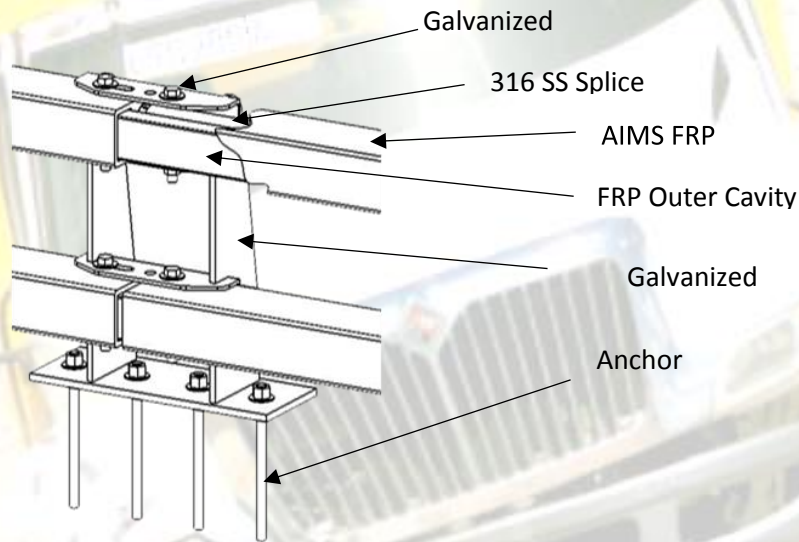

316L or Galvanized Steel

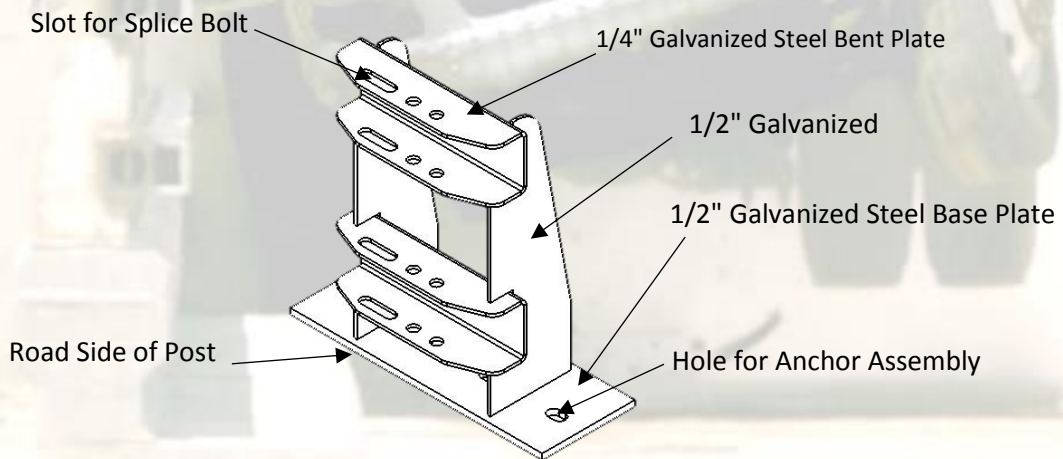

Property in Lengthwise Direction (LW)	Isophthalic Polyester	Test Method
Tensile Strength LW (psi)	33,000	ASTM D638
Tensile Modulus LW (10 ⁶ psi)	2.5	ASTM D638
Flexural Strength LW (psi)	33,000	ASTM D790
Flexural Modulus LW (10 ⁶ psi)	1.6	ASTM D790
Bearing Strength LW (psi)	30,000	ASTM D953
Bearing Strength Crosswise (psi)	18,000	ASTM D953
Modulus of Elasticity (10 ⁶ psi)	3.2	ASTM D638
Heat Distortion Temperature (°F)	160	ASTM D648
In-Plane Shear LW (psi)	7,000	ASTM D2344
In-Plane Shear Crosswise (psi)	4,500	ASTM D2344
Tunnel Test	25 Max	ASTM E-84
Flammability Extinguishing	Self - Extinguishing	ASTM D635

1. Typical Properties of Pultruded FRP Structural Shapes

WWW.AIMS-Intl.com

(281) 590-3240